

## COMPANY PROFILE

- DORNA Technology Co., Ltd was established in 2006. We are strategically located in Jiashan, Zhejiang, which is the heart of Long River Delta and only one hour's drive to Shanghai's Pudong Airport (PVG).
- The production base covers an area of more than 50 Chinese acres and the registered capital of the Company is RMB 50 million. DORNA has a strong work force of over 300 employees consisting of highly educated management teams and skilled workers.
- DORNA possesses numerous independent intellectual property rights and specialize in the research & development, production, sales and service of AC variable frequency drives (inverters), AC servo systems (servo drives & servo motors), stepper drives & motors and rotary encoders.
- Our products have been widely used in CNC machine tools, textile machines, packaging machines, printing machines, food-making and pharmaceutical equipment, carving machines, spring machines, plastic machines, manipulators & robotics etc.
- DORNA will make persistent efforts to create more innovations and offer better products and services for clients. Meanwhile, we are looking forward to cooperate with business partners globally.
- The following content is for reference only and subject to change without prior notifications. Please contact with our Oversea Business Division for latest information: [oversea@cn-dorna.com](mailto:oversea@cn-dorna.com)



**THE LINE-UP**



**TABLE OF COMPARISON**

Features\Series		EPS-B1	EPS-B2	EPS-B5	EPS-M1
Input voltage and power range	220V class	0.05~4.5KW	0.05~3.0KW	0.2~3.0KW	0.4~1.5KW
	380V class	1.5~45KW	N/A	N/A	N/A
Input pulse frequency	<500kbps	Yes	Yes	Yes	Yes
	<4Mbps	Yes	Yes	No	Yes
Control mode	Position control	Yes	Yes	Yes	Yes
	Speed control	Yes	Yes	No	Yes
	Torque control	Yes	Yes	No	Yes
Supported encoder types	20,000ppr incremental	Yes	Yes	Yes	Yes
	20-bit incremental	Yes	Yes	No	No
	17-bit absolute	Yes	Yes	No	No
	Resolver	Yes	No	No	No
Communication	RS-485	Yes	Yes	Yes	Yes
	EtherCAT	Under development	No	No	No

## SERVO DRIVE MODEL IDENTIFICATIONS

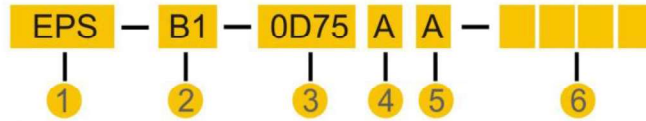

- 1 PRODUCT NAME: EPS
- 2 PRODUCT SERIES: B1/B2/BS/M1
- 3 DRIVE RATED POWER

SYMBOL	DEFINITION	SYMBOL	DEFINITION
0D05	0.05KW	02D2	2.2KW
0D10	0.1KW	0003	3.0KW
0D20	0.2KW	04D5	4.5KW
0D40	0.4KW	05D5	5.5KW
0D75	0.75KW	07D5	7.5KW
0001	1.0KW	0011	11KW
01D2	1.2KW	0015	15KW
01D5	1.5KW	0022	22KW

- 4 INPUT VOLTAGE

SYMBOL	DEFINITION
A	SINGLE/THREE PHASE 220VAC
B	THREE PHASE 380VAC

- 5 HARDWARE VERSION
- 6 FACTORY CODE

## SERVO MOTOR MODEL IDENTIFICATIONS

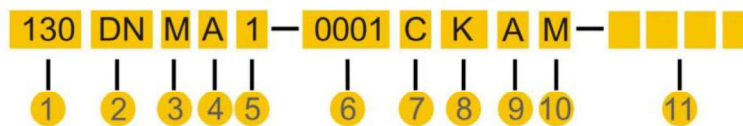

- 1 MOTOR FLANGE (MM)

SYMBOL	DEFINITION	SYM BOL	DEFINITION
40	40 MM FLANGE	130	130 MM FLANGE
60	60 MM FLANGE	180	180 MM FLANGE
80	80 MM FLANGE	200	200 MM FLANGE
110	110 MM FLANGE	220	220 MM FLANGE

- 2 PRODUCT NAME: DN

### 3 MOTOR ROTARY INERTIA

SYMBOL	DEFINITION
M	MEDIUM INERTIA
H	HIGH INERTIA

### 4 VOLTAGE CLASS

SYMBOL	DEFINITION
A	220V VOLTAGE CLASS
B	380V VOLTAGE CLASS

### 5 MOTOR POLE PAIRS

SYMBOL	DEFINITION
1	4 POLE PAIRS
2	5 POLE PAIRS

### 6 MOTOR RATED POWER

SYMBOL	DEFINITION	SYMBOL	DEFINITION
0D05	0.05KW	02D2	2.2KW
0D10	0.1KW	0003	3.0KW
0D20	0.2KW	04D5	4.5KW
0D40	0.4KW	05D5	5.5KW
0D75	0.75KW	07D5	7.5KW
0001	1.0KW	0011	11KW
01D2	1.2KW	0015	15KW
01D5	1.5KW	0022	22KW

### 7 MOTOR RATED SPEED

SYMBOL	DEFINITION	SYMBOL	DEFINITION
A	1000 RPM	D	3000 RPM
B	1500 RPM	E	2500 RPM
C	2000 RPM		

### 8 FEEDBACK DEVICE TYPE

SYMBOL	DEFINITION
K	5000-LINE (LINE SAVING, GAIN )
J	17-BIT SERIAL (ABSOLUTE)
S	20-BIT SERIAL (GAIN)
R	RESOLVER

### 9 MOTOR HOLDING BRAKE SELECTION

SYMBOL	DEFINITION
A	WITHOUT HOLDING BRAKE
B	WITH HOLDING BRAKE

### 10 KEY SLOT/OIL SEAL SELECTION

SYMBOL	KEY SOLT	OIL SEAL
K	YES	NO
Y	NO	YES
M	YES	YES
N	NO	NO

### 11 FACTORY CODE

## EPS-B1 SERIES

- ▶ COMPLETE FUNCTIONS
- ▶ FULL RANGE
- ▶ HIGH PERFORMANCE



## Main features

### FASTER

---

- ▶ Shortened positioning time  
Position setting time of the device can be greatly reduced by using the new algorithms.
- ▶ Quick instruction tracking  
As the new position and speed controller is adopted, position control tracking is greatly improved, and position deviation can be up to  $\approx 0$ .
- ▶ Response frequency up to 1KHz bandwidth  
State-of-the-art chips are utilized to improve calculating speed; new algorithms are developed for speed loop and current loop to improve the servo system's response control performance.
- ▶ Built-in RS-485 communication. EtherCAT under development.

### MORE RELIABLE

---

- ▶ 3 times overload  
EPS-B1 series servo drives have the capacity of 3 times overload, which improves the servo's responsiveness.
- ▶ Grade 2 Notch Filter  
Grade-2 notch filter that can reduce phase lag is used to restrain resonance of mechanical system and improve equipment's speed response.
- ▶ Regenerative functions  
EPS-B1 series servo drives have built-in regenerative resistors (optional) that can absorb regenerated electricity at decelerating. When the built-in regenerative resistor is not enough, external regenerative resistor can be used.

### MORE ACCURATE

---

- ▶ High resolution encoders  
Now EPS-B1 series can support up to 20 bit (1,048,576 pulses per revolution) encoders to improve positioning accuracy and low-speed stability.
- ▶ Load inertia detection  
EPS-B1 series servo drives can automatically detect load inertia for better gain tunings.
- ▶ Fully closed-loop function  
Without the use of any additional module, EPS-B1 can support fully closed-loop control for better mechanical accuracy.

# CONFIGURATION AND INTERFACES

## EPS-B1 AC SERVO SYSTEMS

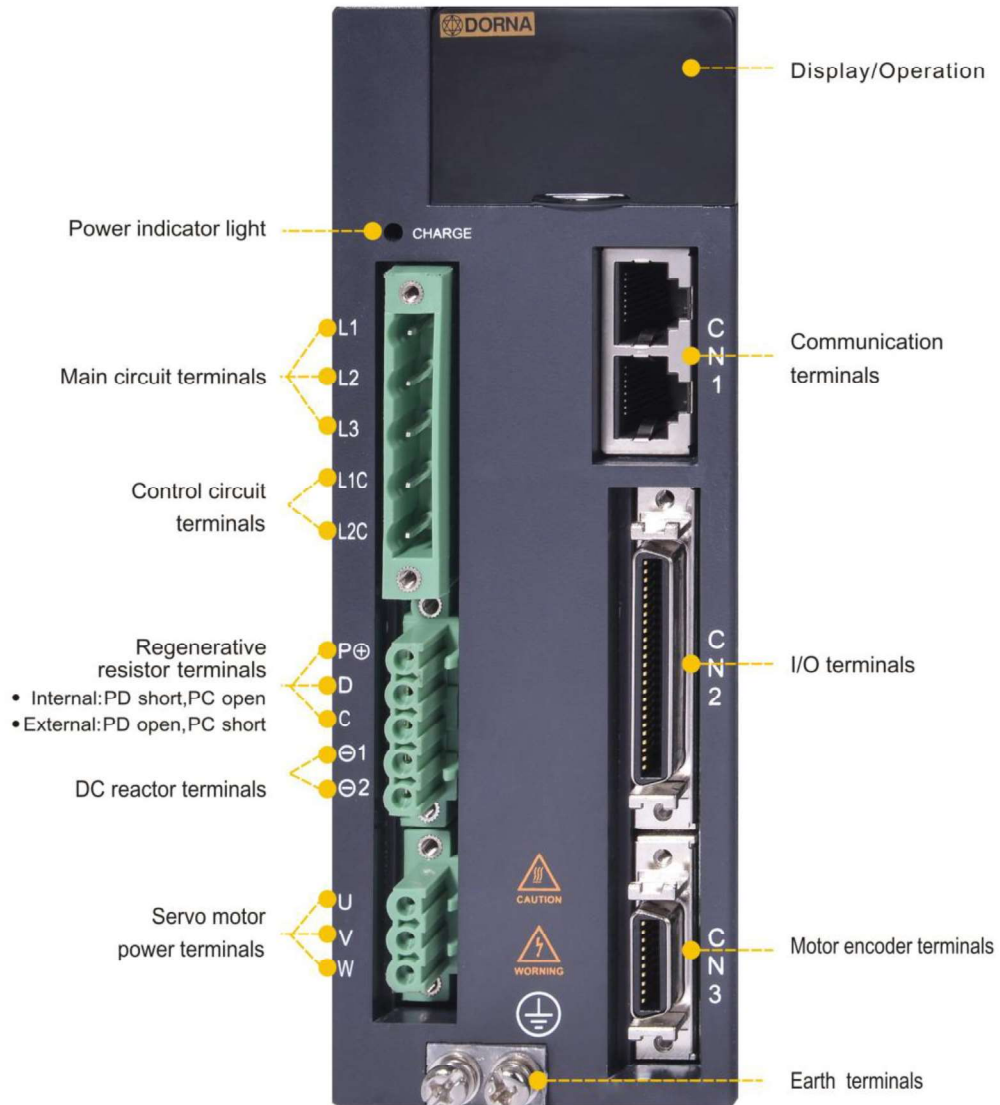

# STANDARD WIRING DIAGRAMS

## EPS-B1 AC SERVO SYSTEMS

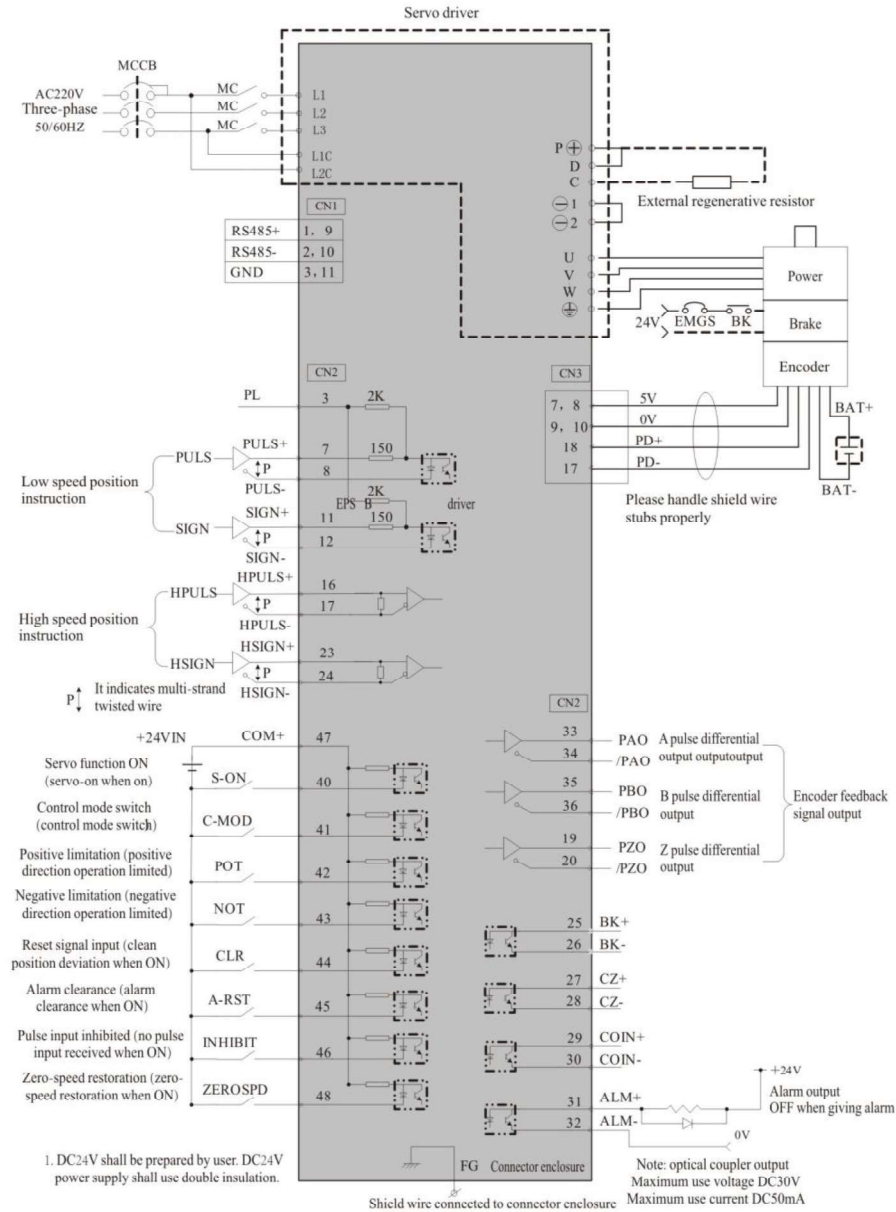

## TECHNICAL SPECIFICATIONS

Basic specifications			
Input voltage	220VAC	Single/Three Phase 220VAC -15%~+10%, 50/60Hz	
	380VAC	Three Phase 380VAC -15%~+15%, 50/60Hz	
Control mechanism		Single/Three phase full wave rectification IGBT PWM control, sine-wave current control	
Feedback devices		5000-LINE (LINE SAVING, GAIN) 17-BIT SERIAL (ABSOLUTE) 20-BIT SERIAL (GAIN) 2500-LINE MAGNETIC	
Use conditions	Ambient temperature	Use temperature: 0~+55°C Storage temperature: -20~85°C	
	Humidity	Below 90%RH (no freezing or condensing)	
	Vibration	4.9 m/s <sup>2</sup> ~19.6 m/s <sup>2</sup>	
	Protection class/cleanness	Protection class: IP10; Cleanness: 2 But should be: · With no corrosive or combustible gas · With no water, oil or drug splashing · With little dust, ash, salt or metallic powder	
	Altitude	Below 1000m	
Applicable standard		CE	
Structure		Pedestal installation type	
Performance	Speed control precision	1:5000	
	Speed fluctuation range	Load fluctuation	0 ~100% load: below ±0.01% (at rated speed)
		Voltage fluctuation	Rated voltage ±10% : 0.001% (at rated speed)
		Temperature fluctuation	25 ± 25°C: below ±0.1% (at rated speed)



## TECHNICAL SPECIFICATIONS

	Torque control precision (repeatable)		±3%
	Soft start time		0~10S (acceleration or deceleration)
Input /output signals	Encoder pulse output		Line drive output: A Phase, B Phase, Z Phase Pulse count: 5000 line-saving encoder: 16~5000; 17 bit serial encoder: 16~16384; 20 bit serial encoder: 16~1,048,576
	Input signals	Pin number	8
		Functions	S-ON, C-MODE, POT, NOT, CLR, A-RST, GAIN, INHIBIT, ZEROSPD, PCL, NCL etc.
	Output signals	Pin number	1 (ALM)
		Pin number	3
		Functions	ALM, COIN, CZ, BK-OFF, S-RDY, etc.
Communication functions	RS485	1:N	With relay, maximum N=31
		Address setting	By parameter setting
		Devices	PC, uppder controller
	EtherCAT		EPS-B1 series only
Display/keypad			7 LED X 5 bit, 4 buttons
Dynamic brake (DB) (optional)			At Servo OFF, forward/backward rotation inhibition, power OFF, or stop due to failure.
Regenerative functions			Internal or external
Over-travel (OT) protections			POT,NOT. DB, deceleration to stop, coast to stop.
Protection functions			Over-current, over-voltage, under-voltage, over-load, regenerative fault, etc.

## SERVO DRIVE DIMENSIONS (UNIT: MM)

**A** A Type case:  
220V class 0.05KW ~ 0.4KW

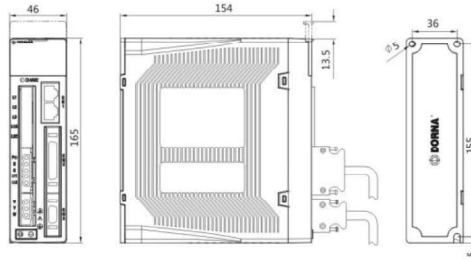

**B** B Type case:  
220V class 0.75KW ~ 1.5KW;  
380V class 0.75KW ~ 1.0KW

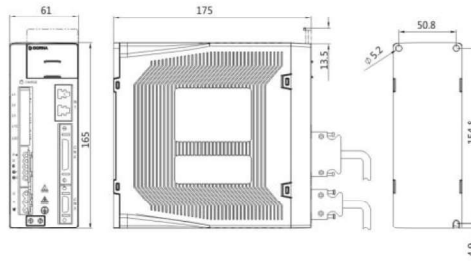

**C** C Type case:  
220V class 2.2KW~3KW;  
380V class 1.2KW ~ 4.5KW

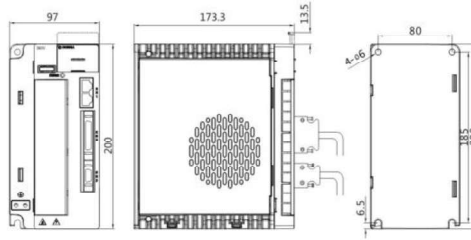

**D** D Type case:  
380V class 5.5KW ~ 7.5KW

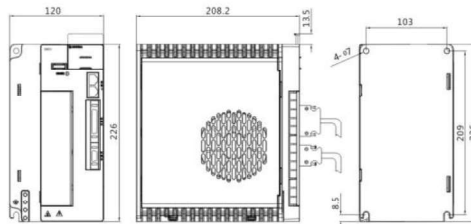

**E** E Type case:  
380V class 11KW~22KW

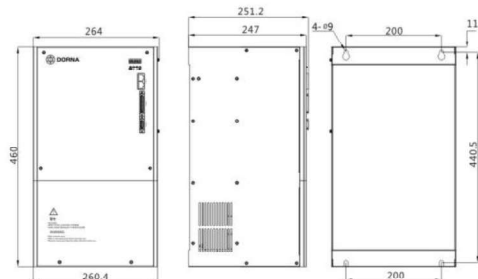

# EPS-B2 SERIES

- ▶ COMPLETE FUNCTIONS
- ▶ HIGH PERFORMANCE

# STANDARD WIRING DIAGRAM

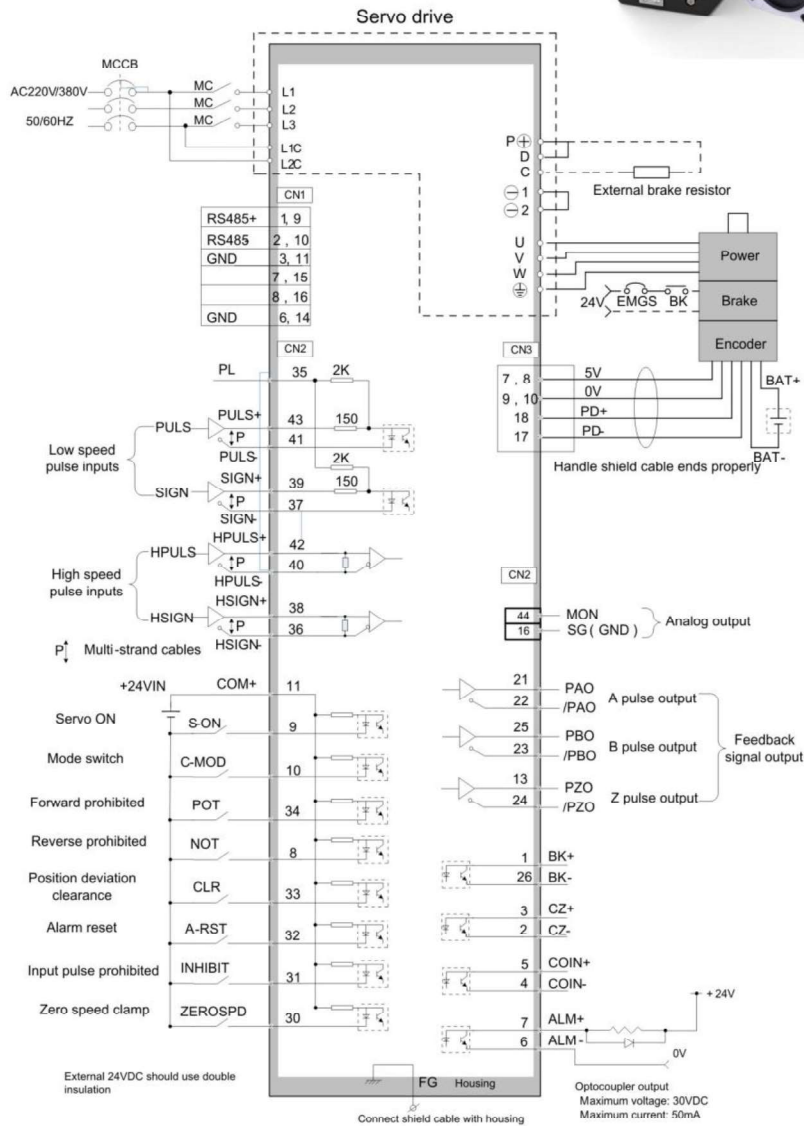

## SERVO DRIVE DIMENSIONS (UNIT: MM)

A Type case: 220V class 0.05KW ~ 0.4KW

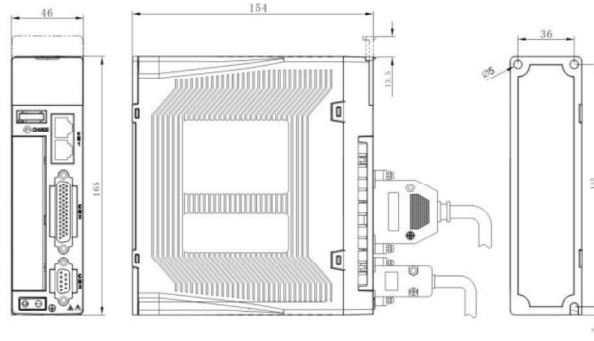

B Type case: 220V class 0.75KW ~ 1.5KW

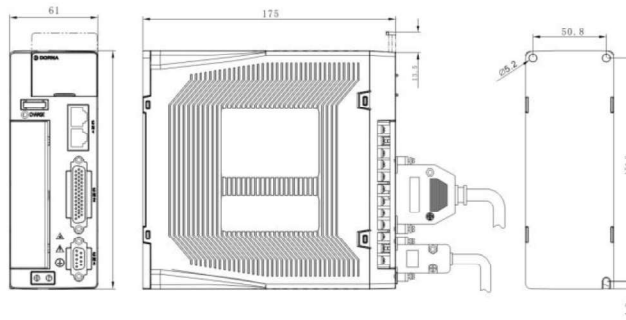

C Type case: 220V class 2.2KW~3KW

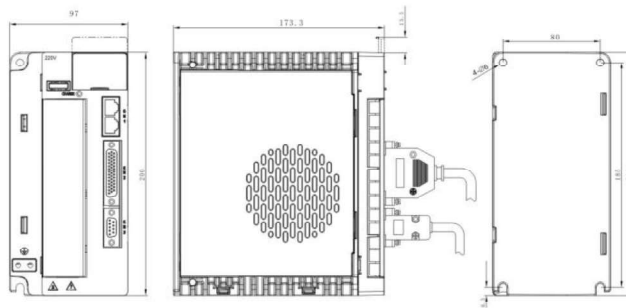

## EPS-BS SERIES

SIMPLE, POWERFUL AND ECONOMICAL

## MAIN FEATURES

- ▶ Dedicated for position control
- ▶ Simple input/output signal interface
- ▶ Simply to use; easy to commission
- ▶ Built-in RS-485 communication



## SERVO DRIVE DIMENSIONS (UNIT: MM)

A Type case:  
220V class 0.2KW ~ 0.4KW

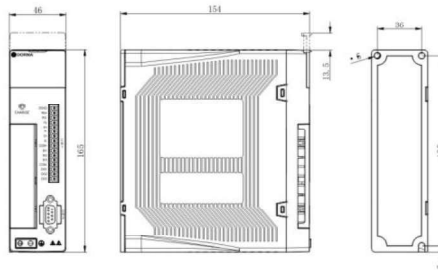

B Type case:  
220V class 0.75KW ~ 1.5KW

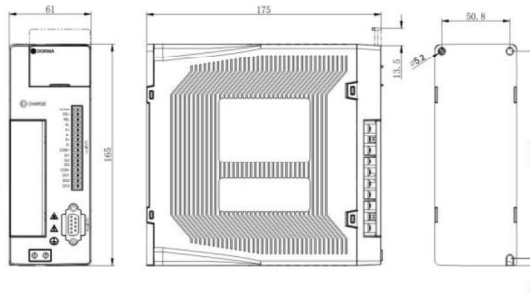

C Type case:  
220V class 2.2KW~3KW

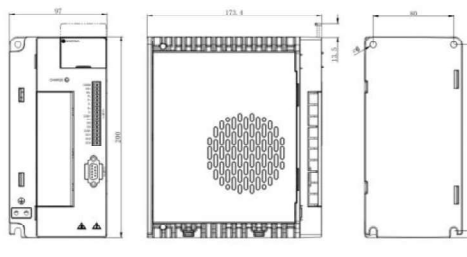

## ■ EPS-M1 SERIES

MULTI-AXIS CONTROL



## ■ MAIN FEATURES

- ▶ Common DC bus technology
- ▶ Space saving, good for cabinets with limited spaces
- ▶ Simply to use; easy to commission
- ▶ Built-in RS-485 communication
- ▶ Cost efficient, cheaper than 3 separate servo sets

## ■ SERVO DRIVE DIMENSIONS (UNIT: MM)

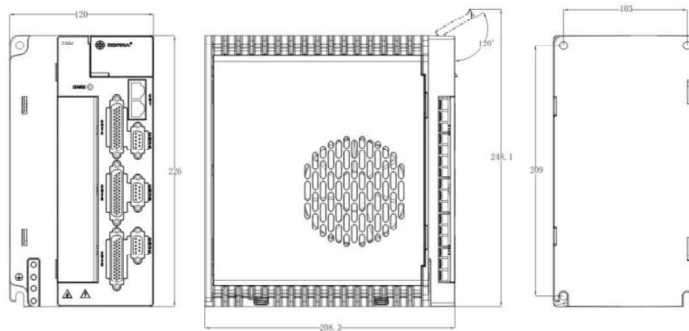

## SERVO MOTOR SPECIFICATIONS & DIMENSIONS

### 40 Series

Servo Motor series	40 series	
Servo Motor model	40DNMA2-0D05D	40DNMA2-0D10D
Input voltage	220VAC	220VAC
Inertia	Medium	
Rated power (W)	50	100
Rated torque (N*m)	0.16	0.32
Rated current (A)	1.1	0.96
Maximum current (A)	5000	5000
Rated speed (rpm)	3.3	2.7
Maximum speed (rpm)	3000	3000
Torque constant (N*m/Amp)	0.14	0.35
Back EMF constant (V/Krpm)	9.5	22.5
Rotary inertia (with brake) ( $10^{-4}$ Kg*m <sup>2</sup> )	0.023 (0.020)	0.048 (0.05)
Resistance (line-line) ( $\Omega$ )	11.4	15
Inductance (line-line) (mH)	10.1	15.8
Mass (with brake) (kg)	0.4 (0.5)	0.6 (0.8)
LL (with brake) (mm)	80.3(117)	105.3(137)
LR (mm)	28	28
LE (mm)	3	3
LG (mm)	7	7
S (mm)	8	8
LJ1 (mm)	0	0
LJ (mm)	6.2	6.2
J (mm)	16	16
LF1 (mm)	3	3
LF2 (mm)	3	3
LM (mm)	M3 deep 8	M3 deep 8
LA (mm)	46	46
LB (mm)	30	30
LC (mm)	40	40
LZ (mm)	4.3	4.3

### Motor outline

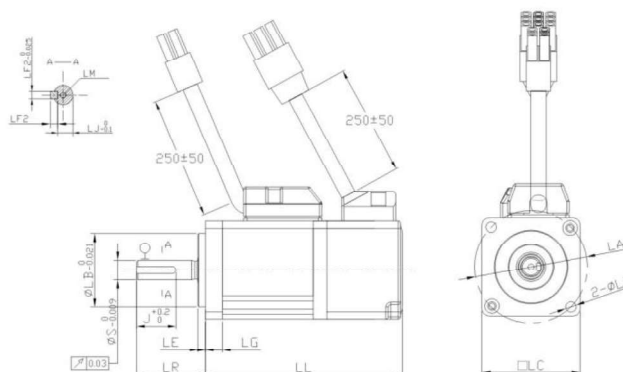

## SERVO MOTOR SPECIFICATIONS & DIMENSIONS

### 60 Series

Servo Motor series	60 series			
Servo Motor model	60DNMA1-0D20	60DNMA2-0D20	60DNMA1-0D40	60DNMA2-0D40
Input voltage	220VAC	220VAC	220VAC	220VAC
Inertia	Medium	High	Medium	High
Rated power (W)	200	200	400	400
Rated torque (N*m)	0.64	0.64	1.27	1.27
Rated current (A)	1.7	1.4	2.9	2.5
Maximum current (A)	5.1	4.2	9	7.5
Rated speed (rpm)	3000	3000	3000	3000
Maximum speed (rpm)	5000	5000	5000	5000
Torque constant (N*m/Amp)	0.37	0.45	0.43	0.508
Back EMF constant (V/Krpm)	24	29	28.7	33
Rotary inertia (with brake) ( $10^{-4}$ Kg*m <sup>2</sup> )	0.14 (0.16)	0.14 (0.16)	0.24 (0.25)	0.67 (0.68)
Resistance (line-line) ( $\Omega$ )	6	8.4	3.8	4.28
Inductance (line-line) (mH)	16	26.5	11	15.4
Mass (with brake) (kg)	1.03 (1.53)	1.03 (1.53)	1.43 (1.89)	1.59 (2.05)
LL (with brake) (mm)	105(140)	105(140)	125(160)	140(175)
LR (mm)	30	30	30	30
LE (mm)	3	3	3	3
LG (mm)	8	8	8	8
S (mm)	14	14	14	14
LJ1 (mm)	0	0	0	0
LJ (mm)	11	11	11	11
J (mm)	20	20	20	20
LF1 (mm)	5	5	5	5
LF2 (mm)	5	5	5	5
LM (mm)	M4 deep 15	M4 deep 15	M4 deep 15	M4 deep 15
LA (mm)	70	70	70	70
LB (mm)	50	50	50	50
LC (mm)	60	60	60	60
LZ (mm)	5.5	5.5	5.5	5.5

### Motor outline

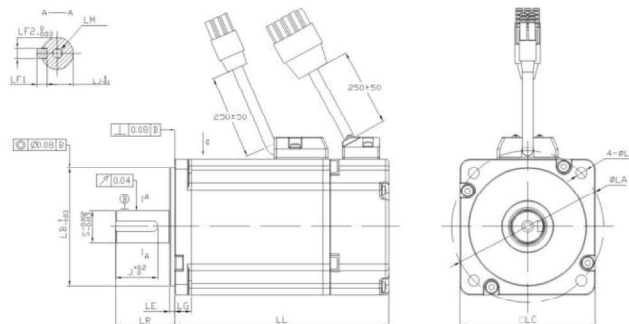



## SERVO MOTOR SPECIFICATIONS & DIMENSIONS

### 80 Series

Servo Motor series	80 Series			
Servo Motor model	80DNMA1-0D75	80DNMA2-0D75	80DNMA1-0001	80DNMA2-0001
Input voltage	220VAC	220VAC	220VAC	220VAC
Inertia	Medium	High	Medium	
Rated power (W)	750	750	1000	1000
Rated torque (N*m)	2.39	2.39	3.18	3.18
Rated current (A)	4.1	3.7	5.5	5.1
Maximum current (A)	12.5	11.1	15.1	15.3
Rated speed (rpm)	3000	3000	3000	3000
Maximum speed (rpm)	5000	5000	5000	5000
Torque constant (N*m/Amp)	0.58	0.64	0.43	0.62
Back EMF constant (V/Krpm)	40	43	40	41
Rotary inertia (with brake) ( $10^{-4}$ Kg*m <sup>2</sup> )	0.88 (0.92)	1.5 (1.53)	1.12 (1.15)	1.12 (1.15)
Resistance (line-line) ( $\Omega$ )	1.5	1.5	1.21	1.2
Inductance (line-line) (mH)	7.9	7.9	6.2	6.1
Mass (with brake) (kg)	2.66 (3.76)	2.93 (4.03)	3.12 (4.22)	3.12 (4.12)
LL (with brake) (mm)	129.7(168.9)	144.7(183.9)	144.7(183.9)	144.7(183.9)
LR (mm)	35	35	35	35
LE (mm)	3	3	3	3
LG (mm)	8	8	8	8
S (mm)	19	19	19	19
LJ1 (mm)	0	0	0	0
LJ (mm)	15.5	15.5	15.5	15.5
J (mm)	25	25	25	25
LF1 (mm)	6	6	6	6
LF2 (mm)	6	6	6	6
LM (mm)	M5 deep 20	M5 deep 20	M5 deep 20	M5 deep 20
LA (mm)	90	90	90	90
LB (mm)	70	70	70	70
LC (mm)	80	80	80	80
LZ (mm)	6.5	6.5	6.5	6.5

### Motor outline

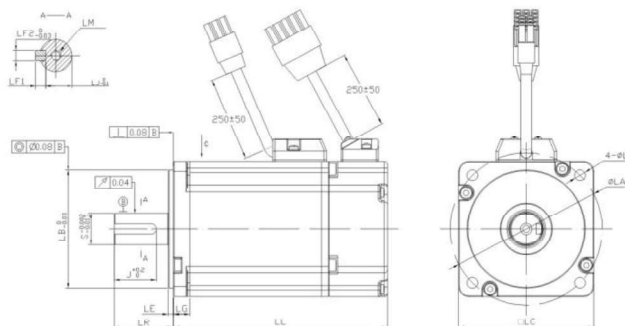

## SERVO MOTOR SPECIFICATIONS & DIMENSIONS

### 110 Series

Servo Motor series	110 Series	
Servo Motor model - new	110DNMA1-0D80C	110DNMA1-01D2C
Servo Motor model - old	110DNA-08C	110DNA-12C
Input voltage	220VAC	
Rated power (KW)	0.8	1.2
Rated torque (N*m)	3.58	5.73
Maximum torque (N*m)	10.74	17.19
Rated current (A)	4	5.6
Maximum current (A)	12	16.8
Rated speed (rpm)	2000	2000
Maximum speed (rpm)	2500	2500
Torque constant (N*m/Amp)	0.90	1.02
Back EMF constant(V/Krpm)	80	78
Rotary inertia (with brake) ( $10^{-4}$ Kg*m <sup>2</sup> )	6.6 (6.7)	8.8 (8.9)
Resistance (line-line) ( $\Omega$ )	2.14	1.5
Inductance (line-line) (mH)	7.45	5.3
Mass (with brake) (kg)	5 (6.3)	6.5 (7.8)
LL (with brake) (mm)	184(236)	204(256)
LR (mm)	40	40
LE (mm)	5	5
LG (mm)	14	14
S (mm)	19	19
LJ1 (mm)	3	3
LJ (mm)	21.5	21.5
J (mm)	25	25
LF1 (mm)	6	6
LF2 (mm)	6	6
LM (mm)	M5 deep 15	M5 deep 15
LA (mm)	130	130
LB (mm)	95	95
LC (mm)	110	110
LZ (mm)	9	9

### Motor outline

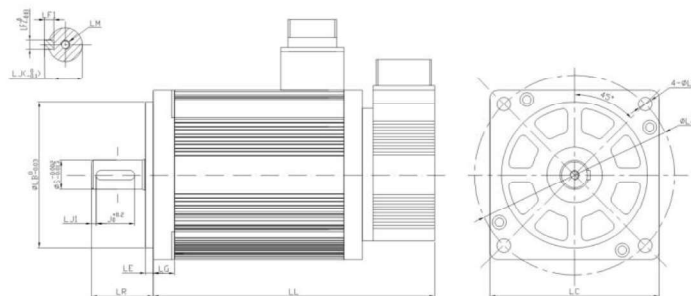

## SERVO MOTOR SPECIFICATIONS & DIMENSIONS

### 130 Series

Servo Motor series	130 Series				
Servo Motor model	130DNMA1-0001C	130DNMA1-01D2C	130DNMA1-01D5C	130DNMA1-02D2C	130DNMA1-0003C
Input voltage	220VAC				
Rated power (KW)	1	1.2	1.5	2.2	3
Rated torque (N*m)	4.77	5.73	7.16	10.5	14.33
Maximum torque (N*m)	14.31	17.2	21.48	31.5	42.99
Rated current (A)	4.9	6.3	8	10.5	16.9
Maximum current (A)	14.7	18.9	24	31.5	50.7
Rated speed (rpm)	2000	2000	2000	2000	2000
Maximum speed (rpm)	3000	3000	3000	3000	3000
Torque constant (N*m/Amp)	0.97	0.91	0.9	1	0.848
Back EMF constant(V/Krpm)	64	64	64	66	64
Rotary inertia (with brake)(10 <sup>-4</sup> Kg*m <sup>2</sup> )	8.3 (8.6)	10.4 (10.7)	12.2 (12.5)	15.6 (15.9)	22.9 (23.2)
Resistance (line-line) (Ω)	1.3	0.9	0.65	0.5	0.27
Inductance (line-line) (mH)	8	6.1	4.7	3.9	2.2
Mass (with brake) (kg)	7.2 (10)	8.2 (11)	9.2 (12)	11 (13.8)	15 (17.8)
LL (with brake) (mm)	172(231)	181 240)	197(256)	219(278)	267(326)
LR (mm)	57	57	57	57	57
LE (mm)	5	5	5	5	5
LG (mm)	13	13	13	13	13
S (mm)	22	22	22	22	22
LJ1 (mm)	0	0	0	0	0
LJ (mm)	24.5	24.5	24.5	24.5	24.5
J (mm)	36	36	36	36	36
LF1 (mm)	6	6	6	6	6
LF2 (mm)	6	6	6	6	6
LM (mm)	M6 deep 15	M6 deep 15	M6 deep 15	M6 deep 15	M6 deep 15
LA (mm)	145	145	145	145	145
LB (mm)	110	110	110	110	110
LC (mm)	130	130	130	130	130
LZ (mm)	9	9	9	9	9

### Motor outline

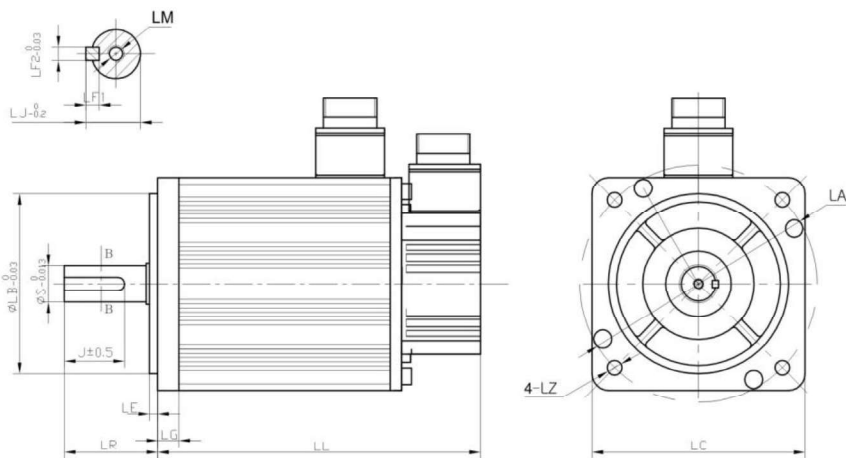

## SERVO MOTOR SPECIFICATIONS & DIMENSIONS

### 130 Series

Servo Motor series	130 Series			
Servo Motor model	130DNMB1-0001C	130DNMB1-01D5C	130DNMB1-02D2C	130DNMB1-0003C
Input voltage	380VAC			
Rated power (KW)	1	1.5	2.2	3
Rated torque (N*m)	4.77	7.16	10.5	14.33
Maximum torque (N*m)	14.31	21.48	31.5	42.99
Rated current (A)	3.2	4.5	6.2	8.7
Maximum current (A)	9.6	13.5	18.6	26.1
Rated speed (rpm)	2000	2000	2000	2000
Maximum speed (rpm)	3000	3000	3000	3000
Torque constant (N*m/Amp)	1.49	1.59	1.69	1.64
Back EMF constant(V/Krpm)	113	120	120	117
Rotary inertia (with brake) ( $10^{-4}$ Kg*m <sup>2</sup> )	8.3 (8.6)	10.4 (10.7)	15.6 (15.9)	22.9 (23.2)
Resistance (line-line) ( $\Omega$ )	3.9	2.02	1.45	0.78
Inductance (line-line) (mH)	25	14	11	7
Mass (with brake) (kg)	7.5 (10.3)	9.6 (12.4)	11.5 (13.3)	16 (18.8)
LL (with brake) (mm)	172(231)	197(256)	219(278)	267(326)
LR (mm)	57	57	57	57
LE (mm)	5	5	5	5
LG (mm)	13	13	13	13
S (mm)	22	22	22	22
LJ1 (mm)	0	0	0	0
LJ (mm)	24.5	24.5	24.5	24.5
J (mm)	36	36	36	36
LF1 (mm)	6	6	6	6
LF2 (mm)	6	6	6	6
LM (mm)	M6 deep 15	M6 deep 15	M6 deep 15	M6 deep 15
LA (mm)	145	145	145	145
LB (mm)	110	110	110	110
LC (mm)	130	130	130	130
LZ (mm)	9	9	9	9

### Motor outline

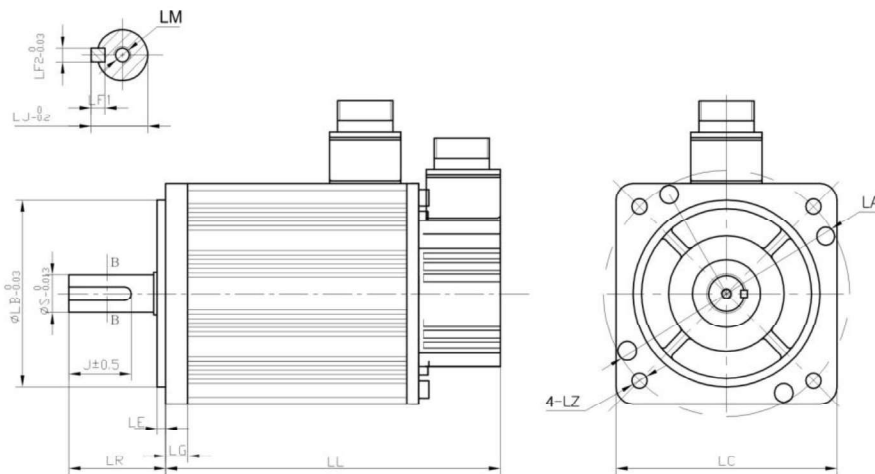

## SERVO MOTOR SPECIFICATIONS & DIMENSIONS

### 130 Series

Servo Motor series	130 Series				
Servo Motor model	130DNMA2-0001C	130DNMA2-01D3B	130DNMA2-01D5C	130DNMA2-0002C	130DNMA2-0003C
Input voltage	220VAC	220VAC	220VAC	220VAC	220VAC
Inertia	Medium				
Rated power (W)	1000	1300	1500	2000	3000
Rated torque (N*m)	4.77	8.27	7.16	9.55	14.33
Rated current (A)	5	9.32	8.4	10.3	13.5
Maximum current (A)	15	28	25.2	30.1	40.5
Rated speed (rpm)	2000	1500	2000	2000	2000
Maximum speed (rpm)	3000	3000	3000	3000	3000
Torque constant (N*m/Amp)	0.95N.m/Arms	0.89N.m/Arms	0.85N.m/Arms	0.93N.m/Arms	1.07N.m/Arms
Back EMF constant(V/Krpm)	66V/Krpm	61.7V/Krpm	59.8V/Krpm	72.6V/Krpm	76V/Krpm
Rotary inertia (with brake)(10 <sup>-4</sup> Kg*m <sup>2</sup> )	7.1 (7.5)	12.1 (12.5)	10.6 (11.1)	13.8 (14.3)	20.4 (20.9)
Resistance (line-line) (Ω)	1.08	0.45	0.543	0.52	0.32
Inductance (line-line) (mH)	12.8	5.7	6.3	6.8	4.7
Mass (with brake) (kg)	6.5 (8.8)	7.6 (9.9)	8 (10.5)	9.6 (11.9)	12.6 (14.9)
LL (with brake) (mm)	154 (198)	182 (226)	173 (217)	192 (236)	230 (274)
LR (mm)	58	58	58	58	58
LE (mm)	6	6	6	6	6
LG (mm)	12	12	12	12	12
S (mm)	22	22	22	22	22
LJ1 (mm)	0	0	0	0	0
LJ (mm)	18	18	18	18	18
J (mm)	36	36	36	36	36
LF1 (mm)	7	7	7	7	7
LF2 (mm)	8	8	8	8	8
LM (mm)	M6 deep 15	M6 deep 15	M6 deep 15	M6 deep 15	M6 deep 15
LA (mm)	145	145	145	145	145
LB (mm)	110	110	110	110	110
LC (mm)	130	130	130	130	130
LZ (mm)	9.5	9.5	9.5	9.5	9.5

### Motor outline

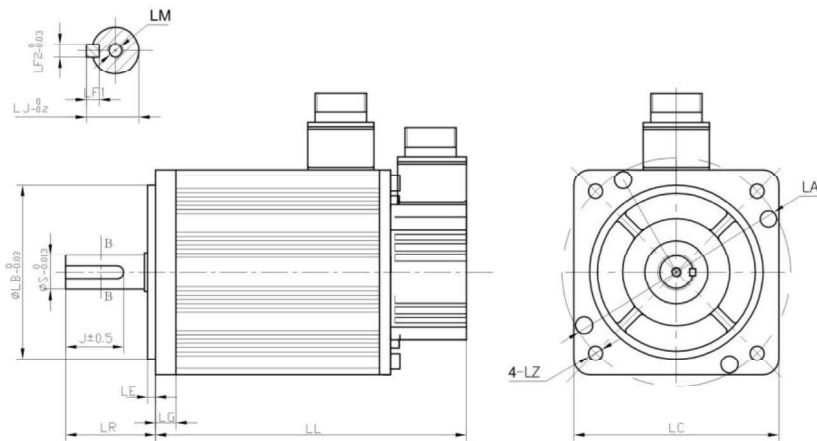

## SERVO MOTOR SPECIFICATIONS & DIMENSIONS

### 180 Series

Servo Motor series	180 Series				
Servo Motor model - new	180DNMA1-0003B	180DNMA1-04D5B	180DNMB1-0003B	180DNMB1-04D5B	180DNMB1-05D5B
Servo Motor model - old	180DNA-30B	180DNA-45B	DNBB18-0003B	DNBB18-04D5B	DNBB18-05D5B
Input voltage	220VAC		380VAC		
Rated power (KW)	3	4.5	3	4.5	5.5
Rated torque (N*m)	19.1	28.6	19.1	28.6	35
Maximum torque (N*m)	57.3	85.8	57.3	85.8	105
Rated current (A)	12	18.4	6.8	10.3	12.5
Maximum current (A)	36	55.2	20.4	30.9	37.5
Rated speed (rpm)	1500	1500	1500	1500	1500
Maximum speed (rpm)	2000	2000	2000	2000	2000
Torque constant (N*m/Amp)	1.59	1.55	2.81	2.78	2.80
Back EMF constant(V/Krpm)	107	112	225	210	200
Rotary inertia (with brake)(10 <sup>-4</sup> Kg*m <sup>2</sup> )	47.7 (48.2)	69 (69.5)	47.7 (48.2)	69 (69.5)	77.5 (78)
Resistance (line-line) (Ω)	0.67	0.32	2.9	1.18	0.88
Inductance (line-line) (mH)	4.65	3.3	21	10	9.4
Mass (with brake) (kg)	19.5 (24.5)	23.5 (28.5)	20 (25)	24 (29)	31.5 (36.5)
LL (with brake) (mm)	212(287)	252(327)	212(287)	252(327)	272(347)
LR (mm)	65	65	65	65	65
LE (mm)	3.2	3.2	3.2	3.2	3.2
LG (mm)	18	18	18	18	18
S (mm)	35	35	35	35	35
LJ1 (mm)	3	3	3	3	3
LJ (mm)	38	38	38	38	38
J (mm)	51	51	51	51	51
LF1 (mm)	8	8	8	8	8
LF2 (mm)	10	10	10	10	10
LM (mm)	M8 deep 20	M8 deep 20	M8 deep 20	M8 deep 20	M8 deep 20
LA (mm)	200	200	200	200	200
LB (mm)	114.3	114.3	114.3	114.3	114.3
LC (mm)	180	180	180	180	180
LZ (mm)	13	13	13	13	13

### Motor outline

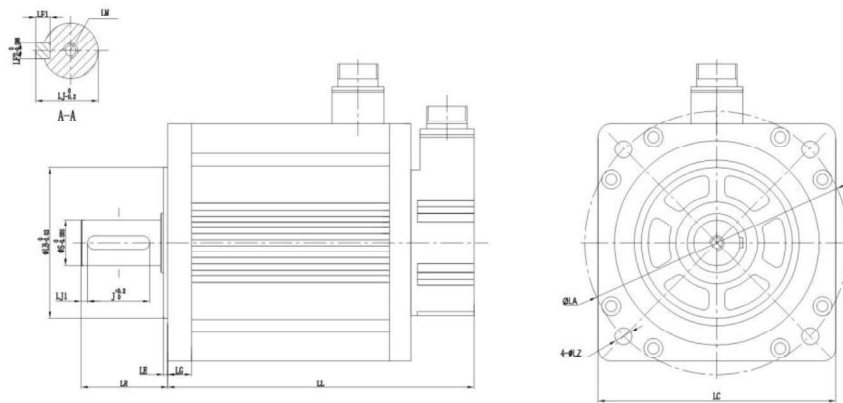

## SERVO MOTOR SPECIFICATIONS & DIMENSIONS

### 200 Series

Servo Motor series	200 Series				
Servo Motor model	200DNMB1-07D3C	200DNMB1-14D7C	200DNMB1-0022C	200DNMB1-29D3C	200DNMB1-0044D
Input voltage	380VAC				
Rated power (KW)	7.3	14.7	22.0	29.0	44.0
Rated torque (N*m)	35	70	105	140	140
Maximum torque (N*m)	105	210	315	420	420
Rated current (A)	13	25	37	55	85
Maximum current (A)	39.8	76.5	113.2	168.3	260.1
Rated speed (rpm)	2000	2000	2000	2000	3000
Maximum speed (rpm)	2400	2400	2400	2400	3200
Torque constant (N*m/Amp)	2.69	2.80	2.84	2.55	1.65
Back EMF constant(V/Krpm)	1.5	1.5	1.5	1.5	1.08
Rotary inertia (with brake) ( $10^{-4}$ Kg*m <sup>2</sup> )	5.5	10	14	17.5	17.5
Resistance (line-line) ( $\Omega$ )	1.2	0.48	0.3	0.18	0.086
Inductance (line-line) (mH)	13	6.08	4.5	2.7	1.58
Mass (with brake) (kg)	35	47	60	72	74
LL (with brake) (mm)	363	433	503	573	573
LR (mm)	82	82	82	82	82
LE (mm)	4	4	4	4	4
LG (mm)	16.5	16.5	16.5	16.5	16.5
S (mm)	42	42	42	42	42
LJ1 (mm)	0	0	0	0	0
LJ (mm)	37	37	37	37	37
J (mm)	66	66	66	66	66
LF1 (mm)	8	8	8	8	8
LF2 (mm)	12	12	12	12	12
LM (mm)	M12 deep 30	M12 deep 30	M12 deep 30	M12 deep 30	M12 deep 30
LA (mm)	215	215	215	215	215
LB (mm)	180	180	180	180	180
LC (mm)	200	200	200	200	200
LZ (mm)	13.5	13.5	13.5	13.5	13.5

### Motor outline

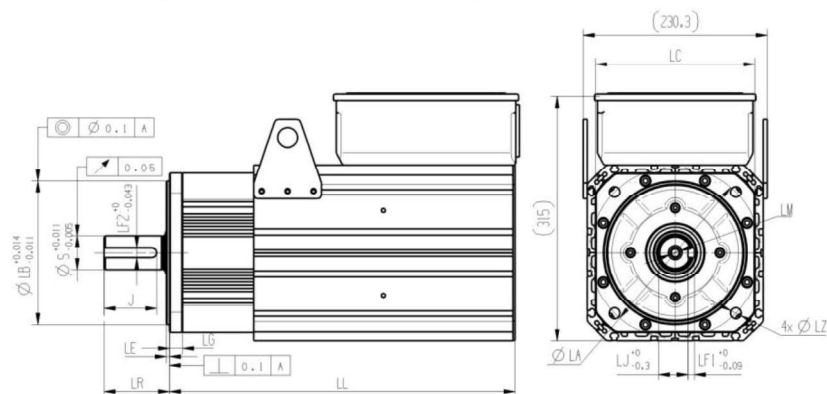

## SERVO MOTOR SPECIFICATIONS & DIMENSIONS

### 200 Series

Servo Motor series	200 Series				
Servo Motor model	200DNMB1-0011D	200DNMB1-0011A	200DNMB1-1407A	200DNMB1-0022D	200DNMB1-0033D
Input voltage	380VAC				
Rated power (KW)	11	11	14.7	22.0	33.0
Rated torque (N*m)	35	105	140	70	105
Maximum torque (N*m)	105	315	420	210	315
Rated current (A)	20	20	25	37	55
Maximum current (A)	61.2	61.2	76.5	113.2	168.3
Rated speed (rpm)	3000	1000	1000	3000	3000
Maximum speed (rpm)	3200	1200	1200	3200	3200
Torque constant (N*m/Amp)	1.75	5.25	5.6	1.89	1.91
Back EMF constant(V/Krpm)	1.08	3.2	3.2	1.08	1.08
Rotary inertia (with brake) ( $10^{-4}$ Kg*m <sup>2</sup> )	5.5	14	17.5	10	14
Resistance (line-line) ( $\Omega$ )	0.5	1.13	0.78	0.21	0.14
Inductance (line-line) (mH)	6.1	18.4	13.1	3.06	2.08
Mass (with brake) (kg)	37	58	70	49	62
LL (with brake) (mm)	363	503	573	433	503
LR (mm)	82	82	82	82	82
LE (mm)	4	4	4	4	4
LG (mm)	16.5	16.5	16.5	16.5	16.5
S (mm)	42	42	42	42	42
LJ1 (mm)	0	0	0	0	0
LJ (mm)	37	37	37	37	37
J (mm)	66	66	66	66	66
LF1 (mm)	8	8	8	8	8
LF2 (mm)	12	12	12	12	12
LM (mm)	M12 deep 30	M12 deep 30	M12 deep 30	M12 deep 30	M12 deep 30
LA (mm)	215	215	215	215	215
LB (mm)	180	180	180	180	180
LC (mm)	200	200	200	200	200
LZ (mm)	13.5	13.5	13.5	13.5	13.5

### Motor outline

